

EZIGRIP

Advantage Bike Rack

For 2 and 4 bike racks

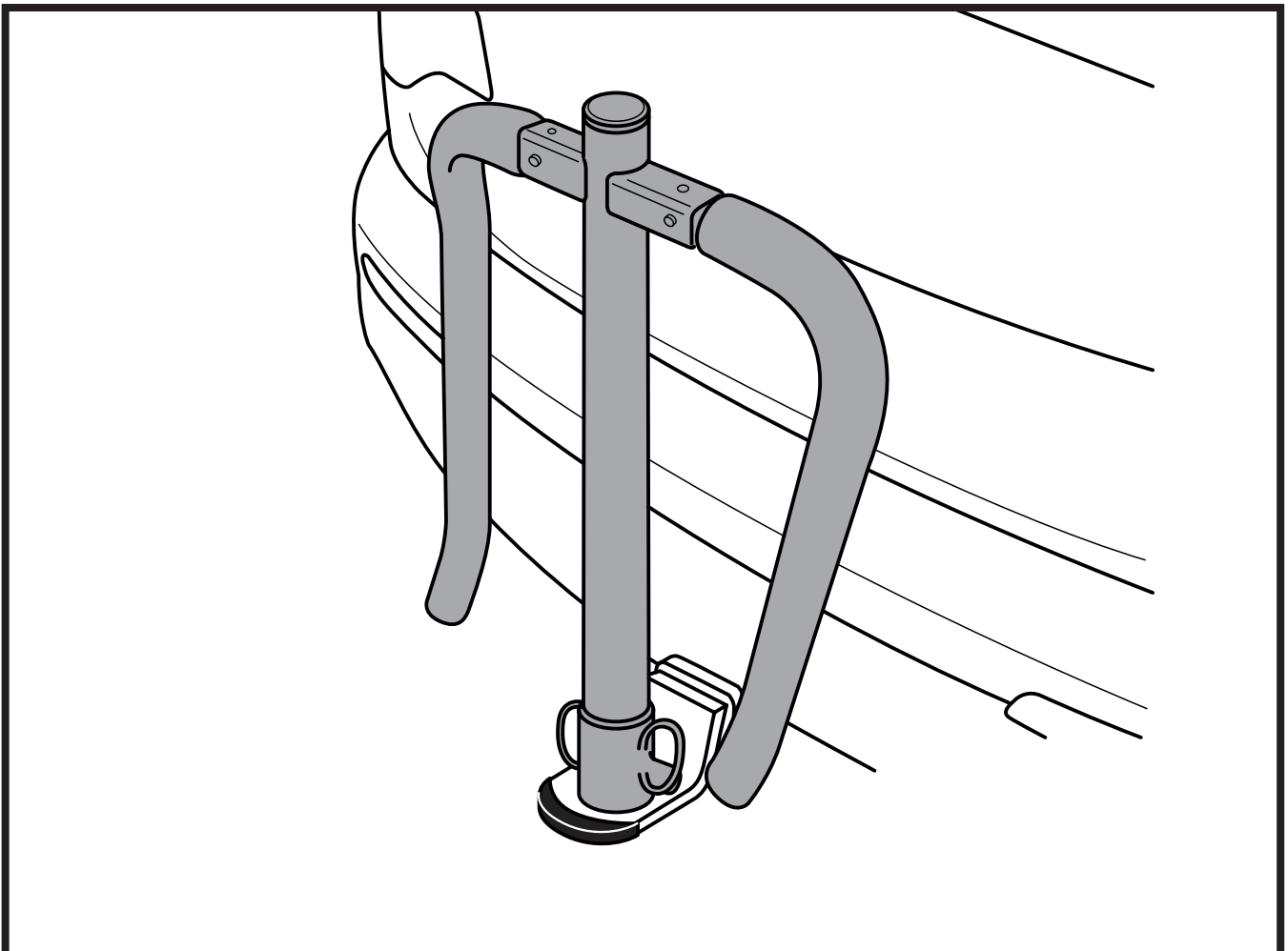

Owners Manual and Fitting Instructions



EZIGRIP

General notes

- Follow these instructions to ensure you correctly fit your Ezi Grip bike rack to your vehicle.
- Do not repair or modify this accessory in any way as this will void the warranty.
- This bike rack is designed for use with both 1"7/8 and 50mm towballs. Ensure the towball fitted to your vehicle is of standard height of 70mm which is measured from the top of the towbar tongue, to the top of the towball. Non-standard tow balls with measurements different from this may result in incorrect fitment of the rack on your vehicle. Do not fit to European 'Gooseneck' style towbars that do not have a platform for the rack base to sit on. If you are unsure please contact the retailer you purchased the rack from.
- Ensure the towball fitted to your vehicle is torqued to the correct setting to prevent the risk of the ball turning once the rack has been fitted. If unsure, visit your local towbar installer to check this.
- It is the owner's sole responsibility to comply with any local laws and regulations that may apply, directly or indirectly, to bicycle racks and the use thereof.
- Clean with soap and water only – DO NOT use solvents or chemicals.
- Check that all work practices comply with safety standards.

Parts Supplied

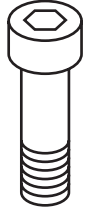
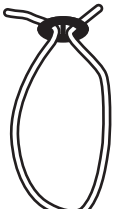
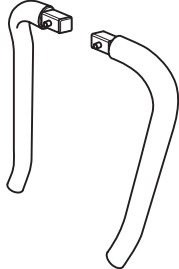
Tools required

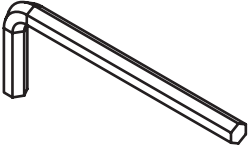
 <p>Cap Screw x2</p>	 <p>Bungee Cord's - X8 (4 bike models) - X4 (2 bike models)</p>	 <p>Arms</p>	 <p>Bike Rack Riser</p>	 <p>Allen Key</p>
---	--	---	--	--

Step 1

- Remove the contents from packaging and place the two Cap Screws into position in the tow ball socket.

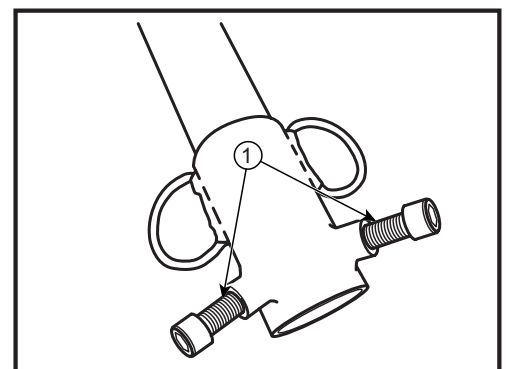

Step 2

- Place the Bike Rack Riser on to the tow ball ②.



Caution

Ensure that the Cap Screws are on the side closest to the vehicle.

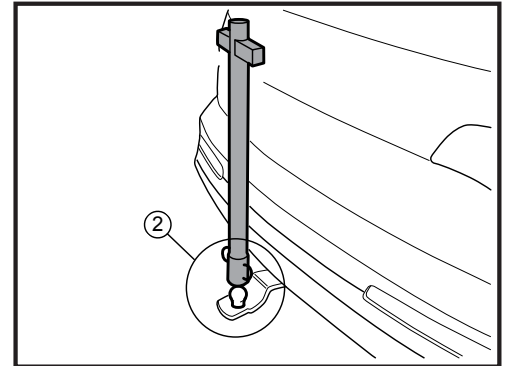

Step 3

- Tighten the two Cap Screws ③ securely onto the tow ball and ensure there is no movement after securing.

Tools used

- Allen Key



Caution

Ensure to regularly check that the Cap Screws remain tight while in use.

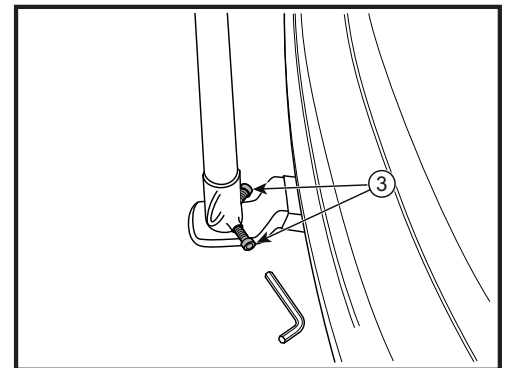

Step 4

- Place the first arm into position. Ensure that it is pushed fully into position and that the Locking Button has located.



Caution

Ensure that the Locking Button is fully into position.

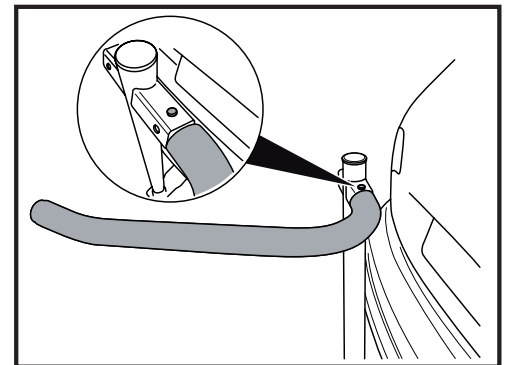

Step 5

- Place second arm into position. Ensure that it is pushed fully into position and that the locking button has located.



Caution

Ensure that the Locking Button is fully into position.

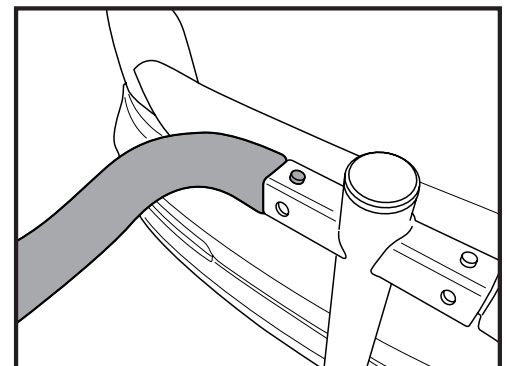

Step 6

- Load bikes onto the rack then ensure that the cycles are well secured with the Bungie Cords.



Caution

Ensure that the Bungie Cords are correctly fitted into the Locking Beads ④.

Ensure no cable brackets or any sharp objects come into contact with the foam as this may cause it to tear. Damage to the foam is not covered under warranty.

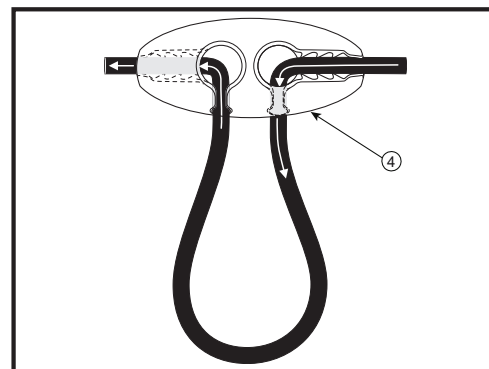

Note

- The owner of the bike rack has the option to be able to move the arms into the down position, for when there are no bikes on the rack. Remove the arms then rotate the arms down 90 degrees. Push the arms back into position, ensuring that the locking button has located.



Caution

Ensure that the Locking Buttons are fully into position.

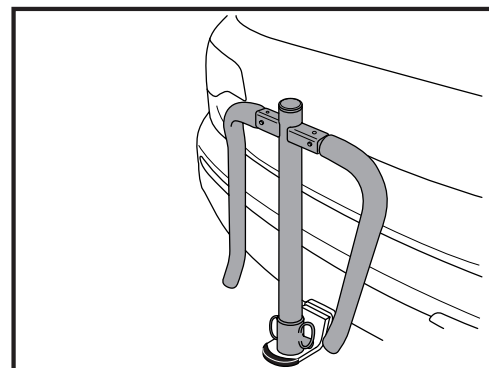

Limited warranty

The manufacturer warrants the Advantage Bike Rack against defects in materials or workmanship for a period of 12 months from date of original purchase. To assert a warranty claim, the owner should return the Advantage Bike Rack to the selling retailer for return to the distributor, freight pre-paid, together with proof of purchase. The owner should include a written explanation of the defect. If the distributor determines that the defect is covered by this warranty, it shall repair or replace the Advantage Bike Rack as it may determine in its sole and absolute discretion, free of charge. This warranty is valid to the original buyer only. It is not transferable or assignable.

You must establish proof of purchase to obtain warranty service or replacement.

This warranty does not cover damage resulting from improper installation, misuse, abuse, neglect, alteration, failure to perform maintenance as instructed or unauthorised repair or service.

The owner is responsible for installing the Advantage Bike Rack in accordance with the installation instructions in the Owners Manual. The owner should attach the Advantage Bike Rack only to towbars for which it has been designed. The manufacturer shall not be liable if the Advantage Bike Rack has been altered, damaged or rendered non-functional through incorrect installation or attachment.

The Advantage Bike Rack is designed to carry bicycles. Do not use the Advantage Bike Rack for purposes other than for which it is designed, or exceed the recommended maximum number and/or weight of bicycles prescribed, as this will invalidate the warranty.

The manufacturer's sole responsibility is to repair or replace a defective part being the subject of a valid warranty claim. Under no circumstance shall the manufacturer be liable for direct, indirect, incidental, special or consequential costs or damages of any kind. Without limiting the generality of the foregoing, the manufacturer shall not be liable for personal injury, property damage or consequential damages resulting from the owner's use of the Advantage Bike Rack. The liability of the manufacturer under any circumstance shall not exceed the original purchase price paid by the owner for Advantage Bike Rack.

This is an express warranty. The manufacturer disclaims any other express or implied warranties, including warranties of merchantability or fitness for purpose, to the maximum extent permitted by law. Statements, representations and specifications in any brochures, sales literature, owners manuals and other documentation concerning the Advantage Bike Rack shall not be deemed warranties, nor shall they extend or expand the manufacturer's obligations under this warranty.

No employee, representative, dealer, agent, distributor or service company acting for the manufacturer has the authority to extend or modify the terms of this limited warranty unless the manufacturer expressly agrees, in writing, to such extension or modification.